

MO-FLEX NURSERY BUILDING PLAN

Plan No. MO4-726-94C1

Developed by: Joseph M. Zulovich, Ph.D., P.E.
Commercial Agricultural Engineer
Animal Structures Specialist
University Extension - Commercial Agriculture Program
Agricultural Engineering Department
University of Missouri

© 1995 University of Missouri

WARRANTY DISCLAIMER:

The plan contained herein provides drawings and recommendations for the nursery building only. The drawings and recommendations are for a building based on 1994 Missouri structural requirements. NEITHER THE UNIVERSITY OF MISSOURI, UNIVERSITY EXTENSION NOR THE COOPERATIVE EXTENSION SERVICE, OR THEIR RESPECTIVE AGENTS OR EMPLOYEES, HAVE MADE, AND DO NOT HEREBY MAKE, ANY REPRESENTATION, WARRANTY OR COVENANT WITH RESPECT TO THE DRAWINGS OR RECOMMENDATIONS HEREIN. Additional professional services will be required to tailor this plan to your situation, including but not limited to:

- assurance of compliance with local codes and regulations;
- development and/or review of specifications for materials and equipment;
- selection of proper site providing adequate natural resource base;
- supervision of site preparation, bid letting and construction;
- development of a manure storage system and nutrient management plan;
- and provisions for utilities, roads and/or other access.

TABLE OF CONTENTS

	<u>Page</u>
WARRANTY DISCLAIMER	ii
Acknowledgments	v
Sizing a MO-Flex Nursery Building	1
Number of Nursery Rooms	1
Size of Nursery Rooms	2
Manure Removal Impact	2
Determining Building Length	3
Structural Specifications for a MO-Flex Nursery Building	5
Structural Lumber Specifications	5
Ceiling Construction	6
Truss Selection	5
Truss Erection	6
General Concrete Specification	6
Reinforcing Steel Requirements	6
Concrete Finishes	7
Insulation Requirements	7
Vapor Retarder Requirement	7
Interior Surfaces	7
Exterior End Walls	8
Interior Partition Walls	9
Post Frame Bracket Installation	9
Manure Removal System Management	10
Flush Systems	10
Pit Recharge Systems	10
Hairpin Gutter Systems	10
Ventilation Specifications for a MO-Flex Nursery Building	11
Ventilation Specifications With No Pit Ventilation	12
Ventilation Specifications Using Pit Ventilation	12
Information for Common Hallway Air Supply	12
Specifications for Heater Requirements	12
Plumbing and Electrical Information	13
ADDITIONAL RESOURCES	14

APPENDICES

A. Missouri Siphon Flush Tanks	16
B. Flush Gutter Water Trap	19
C. Anaerobic Lagoon Systems	20
Submerged Inlet into Lagoon	21
Surface Inlet into Lagoon	22
Wet Well Installation for Lagoon Recycle Pump	23
D. Concrete Manure Storages	24
E. Fan Sizes With No Pit Ventilation	25
F. Fan Sizes Using Pit Ventilation	33
G. Pit Ventilation Pipe Designs for Pit Ventilation	41

Acknowledgments

The author, Joe Zulovich, would like to acknowledge the help of other Commercial Agriculture Swine Team members during the development of this plan. John Hoehne, Commercial Agricultural Engineer (Animal Waste Specialist) and Charles Fulhage, Extension Agricultural Engineer, added input to the manure handling portions of the plan as well as reviewing several other portions of the plan during development. Rick Tubbs, Commercial Agriculture Swine Veterinarian, added input to the management and operational parameters of this plan. Rex Ricketts, Director of the Commercial Agriculture Program, provided a significant amount of additional funding which was used to obtain additional engineering drafting help to complete the drawing portions of the plan.

MO-FLEX NURSERY BUILDING PLAN

See MO-Flex Nursery Building Plan MO4 for related information

The MO-Flex Swine Building System was developed to provide Missouri's independent swine producers with a comprehensive, standardized building plan package using current technology. The MO-Flex Nursery Building is one production stage in the MO-Flex Swine Building System. Plan packages have been developed for each of the four stages of swine production; farrowing, nursery, grow-finish, and breeding-gestation. A plan package includes 20 - 17" x 22" sheets of construction drawings and a manual. The drawings show how a building should be built. This accompanying manual provides additional construction and specification details as well as a discussion of the design, operation and maintenance requirements of the building system.

The MO-Flex Nursery is designed as a single stage nursery which is capable of housing pigs from weaning until pigs are moved to finishing facilities. The MO-Flex Nursery is capable of housing weaned pigs that are 2 to 3 weeks old to growing pigs that are 8 to 11 weeks old. The basic floor plan has multiple rooms with a common hallway along one side of the building. The size and the number of rooms within one building is variable and can be tailored to fit the needs of an operation. A three row pen arrangement is shown for the rooms. However, other arrangements are possible without changing the basic structural design of the building.

Sizing a MO-Flex Nursery Building

The number of head a nursery room holds will depend upon the number of sows weaned as a group and the average litter size. The number of rooms a nursery building will have depends on the length of time a group of pigs will be in the nursery and the farrowing frequency which is the interval between successive farrowings. All-in/All-out management (AIAO) should be planned for use with any new nursery building. AIAO reduces the risk of disease because a given room or building is emptied and cleaned before any new pigs are brought into the room. A nursery space (either a room or building) should be loaded within one week. When a nursery space is emptied, the nursery pigs are usually moved as a group to finishing facilities.

Number of Nursery Rooms

The required minimum number of single stage nursery rooms can systematically be determined. First, management must decide the age at which pigs leave the nursery stage and go to the grow-finish stage. Typical ages that pigs leave the nursery stage ranges from 8 to 11 weeks. Second, the time required to move pigs out of a nursery and clean the room must be determined. The usage time for a nursery room is the total time pigs are in a room plus the time to clean a room. The time pigs spend in a room is determined by subtracting the age pigs leave from the age pigs enter. The required number of nursery rooms can be calculated by dividing the usage time for a room by the farrowing frequency. In equation form, the number of nursery rooms is calculated as follows:

$$MNNR = \frac{NAO + C\&M_{NUR} - WA}{FF} \quad \text{Eq. 1}$$

where: NNR = Minimum number of nursery rooms,
 NAO = Age of pigs leaving nursery (in days),
 C&M_{NUR} = Clean and move for nursery (in days),
 WA = Weaning age (in days),
 FF = Farrowing Frequency (in days).

For example, if the age of pigs leaving a nursery is 70 days (10 weeks), the number of days to clean and move for nursery is 2 days, weaning age is 21 days, and the farrowing frequency is 7 days (weekly), the required number of nursery rooms would be 7.28 $[(70+2-21)/7 = 7.28]$. Since the number of nursery rooms is not an integer (a decimal portion exists), the number of nursery rooms would round up to 8 rooms. However, if the age pigs leaving the nursery were reduced by the number of days to clean and move (2 days), the number of nursery rooms would be exactly 7 $[(68+2-21)/7 = 7]$. By slightly reducing the age pigs leave the nursery, the usage time was reduced to have the result of equation 1 to be an integer value. Management adjustments can be made to the age pigs leave and the time to move and clean to help make the result of equation 1 result in an integer value. The weaning age is usually not changed for nursery scheduling because it may affect the farrowing stage scheduling.

Size of Nursery Rooms

The pen area required for a nursery room is calculated using the number of pigs weaned as a group and the space required per pig in nursery. For single stage nurseries which have 8 to 11 week old pigs leaving the nursery, gross pen area is based on the pig size leaving the nursery and should range from 2.8 ft² to 3.2 ft² per pig. Gross pen area for a nursery room is calculated as follows:

$$GPA = NS \times WA \times SGS \quad \text{Eq. 2}$$

where: GPA = Gross pen area for one nursery room (ft²),
 NS = Nursery space per pig (ft² per pig),
 WA = Average litter size at weaning,
 SGS = Sow group size for sows weaned together.

For example, 30 sows weaned as a group with an average litter size at weaning of nine, the gross pen area for the nursery room would be 810 ft² by assuming 3.0 ft² per pig was provided. The gross pen area for 270 pigs would range from 756 ft² at 2.8 ft² per nursery pig to 864 ft² at 3.2 ft² per nursery pig. Rooms shown on Sheet 2 of the drawings that would provide the necessary gross pen are for this example include rooms with 24 - 4 x 8 pens, rooms with 18 - 4 x 12 pen, and rooms with 30 - 4 x 8 pens.

Manure Removal Impact

Manure should be removed from any swine building on a regular basis. When manure is removed from the building on a frequent basis, the ventilation system can be simplified because pit ventilation (air removal from manure/waste area) is not needed to help maintain indoor air quality.

Flushing under pen flooring is the preferred manure removal system. No pit ventilation is required if flushing frequency for each gutter in a building is two hours or less. The flush system selected will have an impact on building length. Flush systems using flush tanks located inside the building require additional building length. A siphon flush tank design (MO Siphon Tank) developed by Agricultural Engineering at the University of Missouri is included with this plan. This MO Siphon Tank is constructed as an integral part of the building, so it minimizes additional building length. Other available flush tanks having the same capacity as the MO Siphon Tank typically require more building space. This building plan allows for a minimum of 8' additional building length for other available flush tanks. One needs to determine the space requirement of the selected flush tank to insure that enough space is allowed for the tank during this initial building sizing phase. Another flush system design uses overhead pipe storage and therefore does not require additional building length for the system. This overhead storage flush system allows for the absolute minimum building length for the number of pigs housed.

Other manure removal systems available with this plan include pit recharge and gravity drain gutters ("Pull-plug" systems). The pit recharge system is a shallow pit that is filled with a minimum of 12" of recycled water from an anaerobic lagoon after the pit is drained on a regular basis. The gravity drain gutter system is a reversing hairpin gutter that drains the liquid manure either to an outside manure storage or an anaerobic lagoon. These two manure removal options should have mechanical pit ventilation systems. These two manure removal options generally do not impact on the length of the building.

Another consideration for manure removal impact includes the possible manure storage options available at the site a building will be constructed. Flush systems and pit recharge systems assume an anaerobic lagoon is available for manure storage. The gravity drain gutter system can be used in conjunction with an anaerobic lagoon or a liquid manure system. If an anaerobic lagoon cannot be built near the building site, the gravity drain gutter system is the manure option for the building.

Determining Building Length

The total length of a MO-Flex Nursery Building will depend upon the number of individual rooms and the total pig capacity in each room. Different room lengths are shown on Sheet 2 of the drawings. The initial total building length would be the sum of the room lengths that will comprise one nursery building.

The total building length should be in increments of 4' which will help optimize material use. The manure removal option selected may have an impact on building length. If flushing is selected, the total building length will be 4' or 8' longer for the MO Siphon Tank; will be about 8' longer for commercial flush tanks; or will not increase in length for overhead flush storage. If recharge pits or hairpin gutters are selected, the total building length would be the initial length given by the sum of the rooms.

The interior partition walls between the individual rooms do not add length to the building. The walls are assumed to be built using 2x4 construction and would slightly reduce the length of individual rooms.

The alleys running the width of the building in each room can impact building length. Changes in alley width will either increase or decrease building length. If an additional alley is desired in a

room(s), the additional alley(s) will increase total building length. However, alley width or number changes need to be incorporated into a customized floor plan such that the resulting total building length is divisible by four.

Other pen layouts are possible within the basic nursery building plan. If other pen layouts are desired and implemented, care should be used to size the total length of the building such that the total length is divisible by four and that the necessary space for the pigs as well as adequate space for other components comprising the desired nursery floor plan.

Structural Considerations for a MO-Flex Nursery Building

Design loads used for the building structure follow Standard ANSI/ASCE 7-93, Minimum Design Loads for Buildings and Other Structures. The live load for the roof structure was 20 psf (pounds per square foot). Wind loads for the structure were based on an 80 mph wind speed. Appropriate dead loads were included. Structural design details given in this plan meet required load conditions for Missouri. NOTE: If changes are made to structural design of the building, the changes shall be certified by an engineer to insure the proposed changes will provide adequate strength to meet required loads at the location the building is constructed.

The structural design details included in this plan should not be used in areas where either the design roof live load (ie. snow load) or the design wind speed is exceeded. Areas where either the roof live load or the wind speed are exceeded require different structural design details than ones included in this plan. An engineer will be required to redesign and certify the necessary structural changes so that the new design will meet the load conditions of the new area.

Structural Lumber Specifications

Lumber quality of all structural components is to be Number 2 Southern Pine or better. Treated lumber is to be 0.6 PCF CCA treated. Structural components include 2x6 post members, bottom plate, 2x8 bottom girt, 2x10 top girt, and 2x4 purlins. The structural member for this MO-Flex Nursery Building exposed to moisture includes the bottom plate and needs to be CCA treated. The remaining sidewall structural members, which include 2x6 post members, 2x8 bottom girt, and 2x10 top girt, do not need to be CCA treated except for portions of the sidewalls that may have curtains. If a lesser quality of lumber is used, the structural design details may be inadequate and then would require an engineer to redesign the structure for poorer quality lumber.

Ceiling Construction

Construction of the insulated ceiling may be accomplished by several different techniques. Owners and builders should determine with what and how a ceiling is actually constructed. The finished ceiling construction should have an R-value of 30 and have the proper interior surface characteristics. Two acceptable methods are given below.

One method of ceiling construction is to attach 29 ga. corrugated aluminum directly to the bottom chord of the trusses after a vapor barrier is installed. If a metal ceiling construction is used, the truss manufacturer should be notified when purchasing trusses because the ceiling may provide the necessary bottom chord bracing.

Another method of constructing the ceiling is to use a flexible plastic sheet material for the ceiling. The flexible plastic sheet can provide the desired surface characteristics and hold insulation adequately but will not provide bottom chord bracing. Additional framing may be required to provide the necessary bottom chord bracing.

Truss Selection

Trusses for the MO-Flex Swine Buildings have the following specifications:

Roof Slope:	4/12
Loading Criteria:	For insulated ceiling (20#-4#-0#-5#) Top chord live load - 20 psf Top chord dead load - 4 psf Bottom chord live load - 0 psf Bottom chord dead load - 5 psf
Support Width:	41' (Exterior posts are 41'-6" apart [exterior face to exterior face])
Top Chord Overhang:	18" to help protect fans in sidewalls
Truss Spacing:	4' o.c.
Purlins:	For insulated ceiling, 2x4's at 24" o.c. attached flat on top
Bottom Chord Bracing	Follow BWT-76 from Truss Plate Institute. Indicate construction method of ceiling (if used).

Trusses should be purchased from a truss supplier. Truss design should be certified by an engineer to meet the required loading.

Truss Erection

Truss erection and temporary bracing are important considerations during the design process of a truss. However, this component is the most difficult to manage from the building designer's point of view because of differences between construction crews and locations. Even though erection is the most difficult to manage, truss engineering firms are greatly concerned because of the potential loss of human life and property losses due to a construction accident during truss erection. Information on proper truss erection is available from "Bracing Wood Trusses" (BWT-76) and Handling and Erecting Wood Trusses (HET-80). Both pieces are available from the Truss Plate Institute. "Commentary and Recommendations for Handling, Installing and Bracing Metal Plate Connected Wood Trusses" (HIB-91) is another document from the Truss Plate Institute and provides diagrams and specifications for getting trusses safely installed.

General Concrete Specification

Concrete is used in the MO-Flex Nursery Buildings for footings, exterior stub walls, flooring for manure handling systems, interior stub walls and/or concrete siphon flush tanks. Concrete specifications are as follows:

- Minimum 3,500 psi compressive strength (about a 6 bag mix),
- Air-entrained,
- Maximum aggregate size of 1 inch,
- Maximum slump of 4 inches.

This level of concrete quality is required to obtain the desired finishing and durability characteristics.

Reinforcing Steel Requirements

Reinforcing steel should be included in all structural concrete for MO-Flex Nursery Swine Buildings. Structural concrete includes slab on grade construction, footings, exterior structural walls and/or concrete siphon flush tanks. Reinforcing steel is required not only for structural strength but also for temperature and shrinkage reinforcement.

Footings: Footings require two #4 bars running the entire length and located about 8" apart in the lower third of the footing. When footings go around corners, each corner should have #4 dowels to maintain the steel around each corner.

Slabs on Grade: Concrete floors 4" thick require #4 bars at 18" o.c. in both directions and located at the vertical center of the slab.

Exterior Structural Walls: Steel requirements for 8" exterior concrete walls include both vertical and horizontal steel reinforcing. Vertical steel should be #4 bars, 16" on center throughout the length of the exterior walls. Horizontal steel should be #4 bars, 10" on center (maximum) throughout the height of the exterior walls. For 4' high exterior walls, five (5) rows of #4 bars should be used (See sheet F4). For 5' high exterior walls, seven (7) rows of #4 bars should be used (See sheets P3 and/or H3).

Concrete Siphon Flush Tanks: If MO Siphon Flush Tanks are to be built, reinforcing steel requirements are detailed in drawings on sheets F7 and F9. Steel requirements for the siphon flush tank provide structural strength. If the steel requirements are not followed, a tank failure is possible.

Above steel reinforcing requirements are given as general recommendations. Drawings that accompany this plan should be examined to find locational details for reinforcing steel requirements of any particular concrete structural components.

Concrete Finishes

Structural Walls and Siphon Tank: All vertical structural walls, including concrete siphon tank components, should be vibrated during placement of the concrete. Vibrating is required to minimize honeycombing; insure that concrete entirely fills forms and also adheres to all connection and steel reinforcing.

Slabs on Grade: Concrete slabs on grade should be finished to a smooth float finish. The finish should be smooth enough so that manure removal is not inhibited. Also, the finish should be such that no aggregate or holes are left at the top surface to allow manure to easily begin corrosion of the concrete surface.

Alleys or Walkways: Alleys or walkways where human or animal traffic exist should have a non-skid surface. Concrete surfaces for alleys or walkways should first have a smooth float finish and then be completed with light to medium broom finish. The float finish is first required to give a durable surface, and the broom finish is to provide a non-skid surface for traffic.

Insulation Requirements

Insulation levels are shown on the drawings. Insulated components include: building perimeter, exposed concrete walls, frame end walls, and ceiling or roof. Reduced insulation levels from those shown on the drawings will increase heat loss from the building shell and result in higher heating costs.

Vapor Retarder Requirement

A vapor retarder should be placed behind the inside surface material of all insulated building components. An acceptable vapor retarder is 6-mil plastic. The plastic should be continuous and should be either sealed or overlapped at least 6" at joints. Other materials which meet vapor retarder performance of 6 mil plastic may be substituted.

Interior Surfaces

Interior surfaces can be constructed from a variety of materials. Interior surfaces should be non-porous. Surfaces need to withstand repeated high pressure washings using detergents and disinfectants. Typical surfaces include corrugated galvanized metal, corrugated aluminum and glassboard. If pigs will have access to an interior surface, the pig contact area should be covered by a smooth, durable, joint free, pig resistant surface.

Exterior End Walls

Exterior end walls should be constructed as 2x6 stud frame walls using standard framing techniques. The sill plate should be CCA treated and attached to the concrete wall with ½" x 8" anchor bolts at a maximum of 36" on center. Insulation should be placed between the 2x6 studs to provide an R-value of about 19. A vapor retarder should be placed on the inside of the wall just under the interior wall surface. Exterior siding is placed on the outside of the walls.

Interior Partition Walls

Interior partition walls separate any rooms within a building. Several possible methods of constructing interior partition walls exist. One method to construct interior partition walls is presented below as 2x4 stud frame construction. However, any construction practice or methodology that will give the same performance characteristics as the example stud frame construction is acceptable.

A standard 2x4 stud frame construction could be used for all interior partition walls. Bottom sill plate should be CCA treated and lag bolted to the floor. Top sill plate should be framed between bottom chords of adjacent trusses. The framing between trusses for the top plate of partition walls should not interfere with the proper function of the trusses. The 2x4 studs could be placed on either 16" or 24" centers. The selection of surface material will dictate stud spacing. Interior surfaces should be placed on both sides of the 2x4 studs. If pigs will have access to an interior partition wall, the pig contact area should be covered by a smooth, durable, joint free, pig resistant surface. A wall surface is more pig resistant if all joints at pig level are eliminated. Interior partition walls do not need to be insulated.

Post Frame Bracket Installation

The post frame bracket attaches the three 2x6's forming the post to the exterior concrete stem wall. The bracket connection provides a rigid joint at the bottom of the post. No knee braces are required for the design loads because the steel bracket connection provides the necessary lateral wind resistance. The bracket must be installed as shown on the drawings. To aid in construction, a template can be constructed and used to help with placing the four anchor bolts (4 - ½" x 8" anchor bolts) required for each post bracket. The four anchor bolts for each bracket must be properly placed in the exterior concrete stem walls when the concrete walls are constructed. When done properly, the bracket connection will provide a rigid connection between the concrete stem wall and the post frame structure.

The use of the post frame bracket removes the need for knee braces between the trusses and the posts or for interior shear walls. If the post frame bracket is not installed, knee braces or shear walls must be designed into the building to provide lateral wind stability.

Manure Removal System Management

The management of the manure removal system will depend upon the system selected. All available systems remove the manure from the animal space and building to either an anaerobic lagoon system or an outside manure storage facility. Additional information about anaerobic lagoon systems is provided in Appendix C. Additional information about outside manure storages is provided in Appendix D.

Flush Systems

Flush systems require an anaerobic lagoon system. Recycled water from an anaerobic lagoon is used to wash collected manure out from under the pen flooring. A gutter is located under each row of slat and runs the length of the building. Each gutter should be flushed about every 2 hours to help provide for good indoor air quality. However, each gutter should be flushed at least 4 times per day to hydraulically remove the collected manure. If manure build-up under the pen flooring is observed, more frequent flushing of the gutter is required.

MO Siphon Tank: MO Siphon Tank operational and start-up procedures are given in Appendix A. Construction details for a MO Siphon Tank are given in the drawings.

Other Flush Devices: Other flush release devices can be used. Installation and operating information should be obtained from the supplier or manufacturer.

Pit Recharge Systems

Pit recharge systems require an anaerobic lagoon system. When empty, the shallow pits of a pit recharge system are filled with a minimum of 12" of recycled water. Pits should be recharged at a minimum rate of 1" per hour. The recycle pump capacity, in gpm (gallons per minute), can be determined by multiplying the pit floor area in square feet times 0.0104. A recharge pit should be drained and recharged every 5 to 10 days. If the air quality within a building is considered poor, increasing the frequency of draining and recharging the shallow pit will help improve indoor air quality.

Hairpin Gutter Systems

Hairpin gutter systems can be used with either an outside manure storage or an anaerobic lagoon system. The hairpin gutter has two locations where the gutter can be drained. One location should be used to drain the gutter, and then the other location should be used the next time the gutter is drained. This alternating drain procedure helps minimize solids build-up in the gutter. A hairpin gutter can be drained when a minimum of 12" of material is stored in the gutter (about weekly). After a gutter is drained, a minimum of 1" of fresh water should be added to minimize manure from drying and sticking to the gutter floor. The added fresh water helps reduce ammonia level within the building. Ideally, the gutter should have 12" of liquid when elevated ammonia levels are noticed within the building. If elevated ammonia levels are noticed before 12" of liquid is present, add more fresh water when the gutter is initially drained. The additional fresh water will increase ammonia holding capacity of the stored liquid and force the gutter to fill more quickly.

Ventilation Specifications for a MO-Flex Nursery Building

The ventilation performance specifications provide ventilation information for two different mechanical ventilation options. The first ventilation design provides performance specifications for a basic mechanical ventilation system (no pit ventilation) and is recommended for the flush manure handling option. The second ventilation design provides performance specifications for a mechanical ventilation system that includes a pit ventilation system and is recommended for the pit recharge and hairpin gutter manure handling options. Within each ventilation design for a given manure handling option, a range for animal capacities exists, and ventilation performance specifications are provided for a number of probable individual room sizes. Pig capacities range from 120-140 pigs for a single small room to 350-410 pigs for a single large room.

Performance Versus Prescriptive Specifications: The ventilation specifications in this section are performance specifications and not prescriptive specifications. Prescriptive specifications provide the necessary specific details and procedures to purchase and install a given piece of equipment. Performance specifications describe the desired characteristics required for the necessary equipment but do not provide specific prescriptive details which tell exactly which product or brand to use. A performance specification example for a ventilation fan is "The fan should provide 3500 cfm (cubic feet per minute) at 0.10" w.c. (inches of water column) and is typically an 18" diameter fan." But the performance specification does not tell exactly what fan brand or model to purchase.

General Ventilation Performance Specifications: A few general ventilation performance specifications apply for all building options. First, an absolute minimum ventilation rate of 1 cfm per pig is recommended for all options. Second, the minimum ventilation rate should increase to 3 cfm per pig as the pigs grow. A variable, increasing minimum ventilation rate is required because the pigs will grow considerably during the time they are in the facility. As pigs grow, a larger minimum ventilation rate is required. Mechanical ventilation is used for all seasons. The common hallway, as shown, is used to temper incoming cold air during winter conditions. Heaters are required in the hallway to temper incoming air. Additional heaters are required in each room to maintain the proper air temperature because some rooms will be warmer than others and the hallway temperature must be set for the coolest room.

The 6/8" fan size designation indicates that this must be a small capacity (low cfm rating) fan at normal operating static pressures. Most 8" standard or high performance fans have cfm ratings that are too large to serve as the minimum fans for small pig in a nursery room with a low number of pigs. Small fans with low cfm ratings are available from some manufacturers.

These low cfm fans are required for the minimum ventilation rates of newly weaned pigs in a nursery room. If a low cfm fan is not installed, a higher cfm fan will over ventilate the nursery when housing small pigs. Over ventilation leads to unnecessarily increased heating costs as well as probably causing the nursery to be too dry which can lead to added dust problems.

Ventilation Specifications With No Pit Ventilation

Fan recommendations for the various nursery room sizes are given in Appendix E.

Inlet system must match the fan capacity installed for a particular installation. Review the drawings of this plan for general inlet placement information.

Ventilation Specifications Using Pit Ventilation

Fan recommendations for the various nursery room sizes are given in Appendix F when pit ventilation is selected. Pit ventilation exhaust pipe designs are provided in Appendix G. A pit ventilation fan will need to be selected based on the pipes used in the system and how a manifold system is designed and built for a particular installation. These pit ventilation details are construction and equipment specific which makes it beyond the scope of the general ventilation recommendations incorporated in this plan.

Inlet system must match the fan capacity installed for a particular installation. Review the drawings of this plan for general inlet placement information.

Information for Common Hallway

Hallway Purpose: The common hallway serves several purposes. First, it provides access to the individual rooms from a conditioned air space (not outside access). During cold weather conditions, the hallway serves as a chamber to temper air which will enter the individual rooms through the duct in the attic. A disadvantage that has been indicated for a common hallway is related to animal flow. Pigs which are to leave the building would go through the common hallway and "contaminate" the air supply for rooms with smaller pigs. An exterior door is indicated in this plan for each room. Pig which are to leave the building are moved from the room through the exterior door directly to the outside. By leaving directly to the outside, exiting pigs would not "contaminate" the air supply in the hallway.

Air Supply: Air must be able to enter the common hallway to ventilate the rooms. During cold weather, an eave inlet is installed to allow air to enter the hallway. The inlet can direct the cold fresh air down along the exterior hallway wall. By directing the air down along the outside wall, any plumbing along the ceiling of the hallway will be protected somewhat from freezing because cold air will not be blowing on the water pipes.

Specifications for Heater Requirements

Supplemental heating will be required for this plan. Heat can be added in either the common hallway, individual rooms or split between both. Specific heater sizes will depend upon the specific installation. Heater capacity can be estimated as 350 BTU/hr per nursery pig capacity. For example, a 240 pig nursery room will need about 84,000 BTU/hr heater capacity that is provided in the room, or split between the room and common hallway.

Plumbing and Electrical Information

Plumbing drawings are not included in the plan package. The exact water source for a building will be site specific. Since the source of fresh water and any filtering or treatment requirements for the building is unknown, plumbing drawings can not be developed for a general plan. Also, washing equipment requirements will be different for different brands and models and require different plumbing requirements. Washing equipment selection is left to the building owner. After knowing specific water source and washing equipment information, a plumbing plan can be developed.

Electrical drawings are not included in the plan package. Since specific equipment cannot be specified, electrical drawings cannot be developed. The exact electrical diagram requirements will depend upon the specific equipment selections and requirements. Additional information regarding electrical wiring is available from Agricultural Wiring Handbook (Hiatt, 1993), which covers wiring design issues, and Farm Buildings Wiring Handbook (Midwest Plan Service, 1992), which covers wiring installation issues.

ADDITIONAL RESOURCES

- ACI. 1989. Building Code Requirements for Reinforced Concrete and Commentary (ACI 318-89). American Concrete Institute. Detroit, MI.
- Ahrens, D. L. 1976. Concrete and Concrete Masonry. Hobar Publications. Division of Hobar Enterprises, INC. St. Paul, MN.
- AISC. 1989. Manual of Steel Construction, Allowable Stress Design, 9th Edition. American Institute of Steel Construction, Inc. Chicago, IL.
- Albright, L. D. 1990. Environment Control for Animals and Plants. ASAE Textbook No. 4. American Society of Agricultural Engineers. St. Joseph, MI.
- ASAE. 1990. STANDARDS 1990, Standards, Engineering Practices and Data. 37th Edition. American Society of Agricultural Engineers. St. Joseph, MI.
- ASCE. 1993. Minimum Design Loads for Buildings and Other Structures. ASCE 7-93. American Society of Civil Engineers. New York, NY.
- ASHRAE Handbook of Fundamentals. 1989. American Society of Heating, Refrigerating, and Air Conditioning Engineers, Inc. Atlanta, GA.
- Driggers, L. B. 1990. Ventilation of Swine Buildings Using the North Carolina Underslat Ventilation System. The North Carolina State Agricultural Extension Service. North Carolina State University. Raleigh, NC.
- Gustafson, R. J. 1988. Fundamentals of Electricity for Agriculture, 2nd Edition. American Society of Agricultural Engineers. St. Joseph, MI.
- Heber, A. J. 1995. "Mismatched Fans Throw Ventilation Out of Whack." National Hog Farmer. Vol. 40, No. 4. March 15, 1995.
- Hellickson, M. A. and J. N. Walker. 1983. Ventilation of Agricultural Structures. ASAE Monograph 6. American Society of Agricultural Engineers. St. Joseph, MI.
- Hiatt, R. S. 1993. Agricultural Wiring Handbook (Tenth Edition). National Food and Energy Council. Columbia, MO.
- Midwest Plan Service. 1983. Swine Housing and Equipment Handbook (MWPS-8). Midwest Plan Service. Ames, IA.
- Midwest Plan Service. 1983. Revised 1987. Structures and Environment Handbook (MWPS-1). Midwest Plan Service. Ames, IA.
- Midwest Plan Service. 1989. Farm and Home Concrete Handbook (MWPS-35). Midwest Plan Service. Ames, IA.

- Midwest Plan Service. 1990. Mechanical Ventilating Systems of Livestock Housing (MWPS-32). Midwest Plan Service. Ames, IA.
- Midwest Plan Service. 1990. Heating, Cooling and Tempering Air for Livestock Housing (MWPS-34). Midwest Plan Service. Ames, IA.
- Midwest Plan Service. 1992. Farm Buildings Wiring Handbook (MWPS-28). Midwest Plan Service. Ames, IA.
- Midwest Plan Service. 1994. Concrete Manure Storages Handbook (MWPS-36). Midwest Plan Service. Ames, IA.
- NDS. 1993a. NDS "National Design Specification for Wood Construction, Revised 1991 Edition." American Forest and Paper Association. Washington, DC.
- NDS. 1993b. NDS Commentary "Commentary on the National Design Specification for Wood Construction, Commentary on the 1991 Edition." American Forest and Paper Association. Washington, DC.
- NDS. 1993c. NDS Supplement "Design Values for Wood Construction, Revised Supplement to the Revised 1991 Edition." American Forest and Paper Association. Washington, DC.
- Parker, H. 1975. Simplified Engineering for Architects and Builders, 5th Edition. John Wiley & Sons, Inc. New York.
- Pork Industry Handbook. Purdue University Cooperative Extension Service. West Lafayette, IN.
- Truss Plate Institute (TPI). 1976. Bracing Wood Trusses: Commentary and Recommendations. BWT-76. Madison, WI.
- Truss Plate Institute (TPI). 1980. Handling and Erecting Wood Trusses: Commentary and Recommendations. HET-80. Madison, WI.
- Truss Plate Institute (TPI). 1991. Commentary and Recommendations for Handling, Installing and Bracing Metal Plate Connected Wood Trusses. HIB-91. Madison, WI.
- Walker, J. N. and F. E. Woeste. 1992. Post-Frame Building Design. ASAE Monograph 11. American Society of Agricultural Engineers. St. Joseph, MI.
- Wang, C. K. and C. G. Salmon. 1985. Reinforced Concrete Design, 4th Edition. Harper and Row, Publishers. New York.

A. Missouri Siphon Flush Tanks

Flushing is the preferred means of removing manure from MO-Flex Swine Buildings, and siphon flush tanks have attained preference as a water release device due to their simplicity and durability. A few commercially built siphons are available, and if properly sized and installed, work quite well. In Missouri, we have had considerable success with a "home-made" siphon design. Drawings are included in this plan to build MO Siphon Tanks as an integral part of the building structure. However, other water release devices can be used with MO-Flex Swine Buildings.

MO Siphon Tank Components

Although detailed knowledge of siphon operation is not necessary for construction of a siphon, a basic understanding of how a siphon works can help in judging its application and feasibility for a particular individual. The "Missouri" siphon tank consists of the following basic components as noted below and shown in figure 1.

1. Tank
2. Bell with Vent Hole
3. Discharge Pipe
4. Trigger Tube
5. Trap

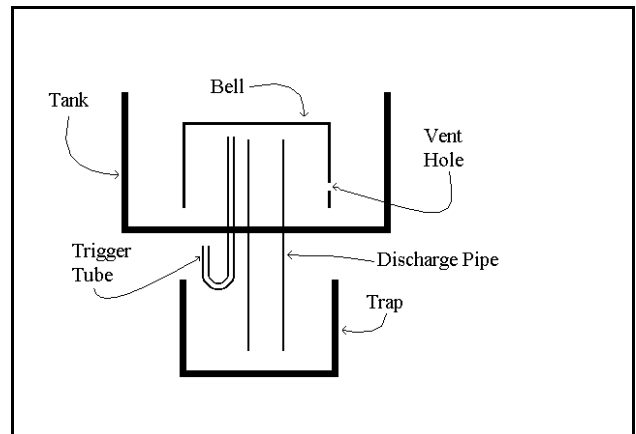

Figure 1. Siphon Tank Components

Siphon Tank Operation

The operational sequence of the Missouri Siphon Flush Tank is described in the following section. The simplicity of this siphon tank is realized by understanding the operation. No moving parts exist with the operation of the tank.

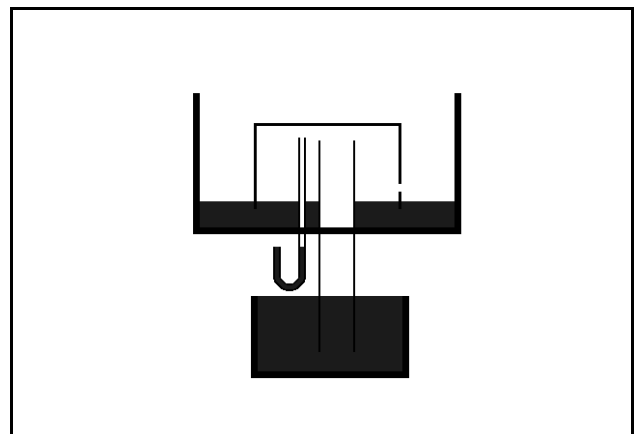

Figure 2. Beginning of Fill

The sequence of operation of the siphon tank begins with the tank filling with water as shown in figure 2. At the beginning of fill, subsequent to a prior flush, water occupies the shaded portions of the system. As the tank continues to fill, water covers the vent hole in the bell and a specific volume of air is trapped under the bell and in the discharge pipe. After the vent hole is covered, the water level under the bell rises at a slower rate than the water level in the tank. Also, the water levels in the discharge pipe and trigger tube are "pushed downward" by air pressure as water rises inside the bell.

Figure 3 shows the water levels in the various components of the siphon tank during the filling process. The water level in the tank will continue to rise faster than the water level under the bell. Also, the water levels will continue to drop in the trigger tube and discharge pipe until the tank is full.

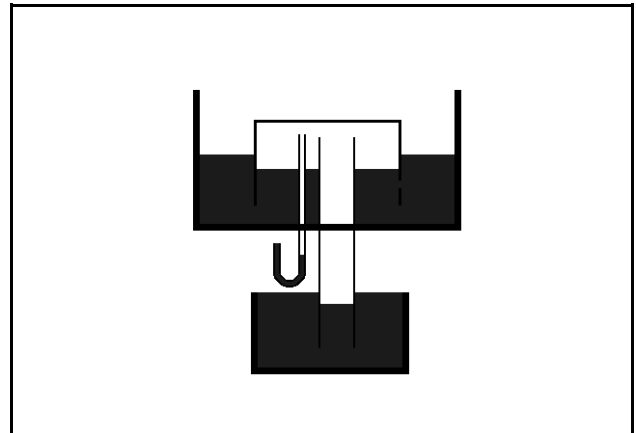

Figure 3. During the Fill

At the end of the fill cycle, water levels are as shown in the figure 4. At the end of fill, air is "pushed" around the bottom of the "U" in the trigger tube. This blows the remaining water out of the "up" leg of the trigger tube and allows the air to escape from under the bell. When air is purged from the system, water fills the area under the bell and the discharge pipe, and flow begins.

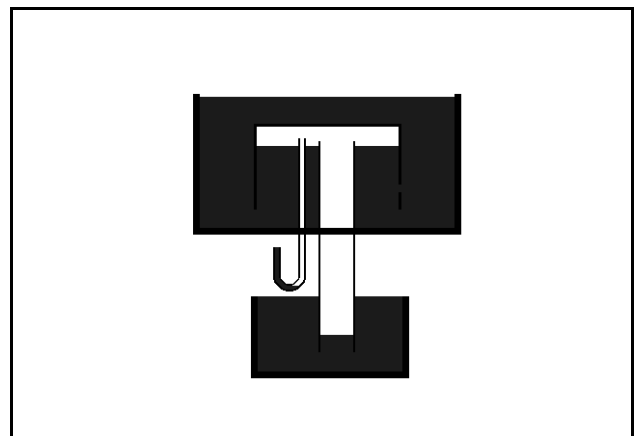

Figure 4. End of Fill

At the beginning and during flow water occupies the area under the bell as shown in figure 5.

After flow is established, the water level in the tank continues to drop until air enters the system underneath the bottom edge of the bell, and the siphon "breaks." Since the vent hole is exposed at this point, air is admitted into the bell until atmospheric pressure exists and conditions are correct for the next fill cycle as shown in figure 1. If properly installed, the trigger tube will refill with water during the tank discharge cycle as shown in figure 5.

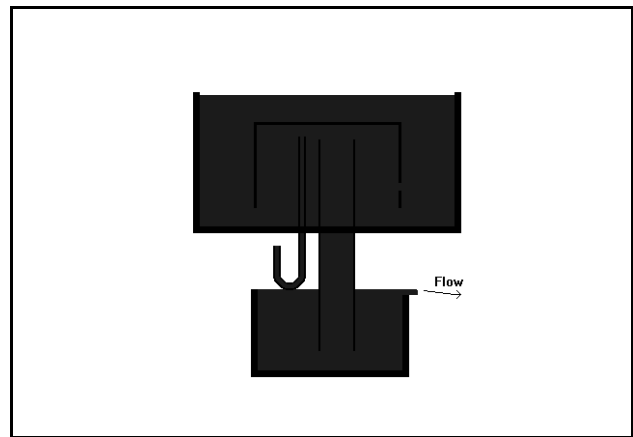

Figure 5. Beginning of Flow

By examining figures 1 through 5, one can ascertain that rather precise dimensions and construction/installation techniques are necessary in order to insure that the Missouri Siphon Flush Tank operates properly. Some of the parameters which are critical to siphon design and operations include:

1. Tank area in plan view and tank depth
2. Bell area in plan view and number of bells
3. Discharge pipe diameter and number of pipes
4. Trigger tube diameter
5. Depth of tank
6. Vent hole diameter and placement
7. Distance discharge pipe extends into tank
8. Distance discharge pipe extends into bell
9. Height of bell above bottom of tank
10. Length of "open" leg of trigger tube.

Siphon flush tanks **MUST** be built strictly according to plans to insure proper operation.

Siphon Tank Start-up Procedure

This start-up procedure insures that the tank will flush at the desired level by accounting for construction tolerances.

1. Make the "up" leg of the trigger tube 2" longer than indicated on the plan.
2. Fill trigger tube and sump. Then fill tank with fresh water to desired level and shut off water.
3. Drill ¼" holes in ¼" increments down from the top edge of the "up" leg of the trigger tube until tank flushes. For safety, use a cordless drill due to the wet environment.
4. Cutoff trigger tube pipe at last hole drilled when tank flushed.
5. Use fresh water during the start-up procedure.

B. Flush Gutter Water Trap

A water trap is required to isolate the air spaces and ventilation systems between adjacent rooms served by a common flush gutter. Different water trap designs are possible. A recommended flush gutter water trap is shown below.

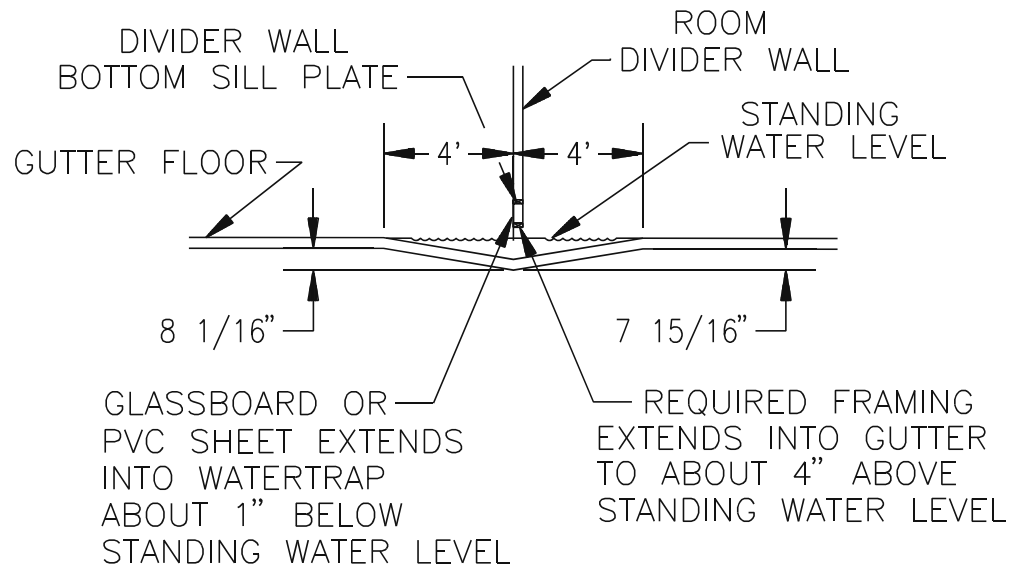

Figure 6. Scaled Sketch of Flush Gutter Water Trap

The above water trap isolates ventilation systems in adjacent rooms while allowing the flush water to pass under the interior partition wall (divider wall) from room to room. The isolation is accomplished by the glassboard extending about 1" into the standing water.

The glassboard is located on the "uphill" side of the divider wall and protects the wall from flush water splashing against the wall. The wall sill plate and the framing that extends the wall into the gutter channel should be constructed using CCA treated lumber. The gutter floor slope is continuous from one side of the trap to the other. Up to three of the above water traps can be placed in one continuous gutter.

If more than three traps are required, the flush volume should be increased to insure an adequate flush flow is maintained throughout the length of the gutter. The flush volume can easily be increased when using the MO Siphon Flush Tank by lengthening the flush tank length by 1' over the length of the tank recommended on the flush tank drawings (Sheets F5, F8 or F9).

C. Anaerobic Lagoon Systems

Anaerobic lagoon systems are a popular manure storage and treatment option for Missouri. Anaerobic lagoons are earthen structures that must be designed and built to meet Missouri Department of Natural Resources regulations. An anaerobic lagoon system is needed for use with flush and pit recharge manure handling and removal systems. A hairpin gutter manure system can also be used with an anaerobic lagoon.

PVC pipe is recommended to connect manure handling systems from building(s) to the anaerobic lagoon. A submerged inlet, shown in Figure 6, allows effluent to flow into an anaerobic lagoon without the potential of cold air entering a building through the drain line. A submerged inlet can help reduce odor potential from manure effluent draining from a building. A surface inlet, shown in Figure 7, can be used instead of a submerged inlet.

A recycle pump system will be required for both a flush and a pit recharge manure system. The recycle pump used for a recycle system should be a submersible, sewage ejector type of pump. A sewage ejector pump has larger impeller tolerances which allow the pump to operate longer between services. A wet well, shown in Figure 8, is located in the anaerobic lagoon bank to supply the recycle water. A wet well installation allows for easier maintenance of the recycle pump. To service the pump, one can simply lift the pump from the wet well instead of having to either drag the pump out of the lagoon or raft out onto the lagoon.

The build-up of salt crystals (struvite) is a common problem when using recycle systems. An acid cleaning system should be considered to help maintain any recycle system. Muriatic acid solution (a 10% hydrochloric acid) can be circulated through a recycle system to dissolve the struvite. If a wet well is used, the acid cleaning system can be relatively easily incorporated into the recycle system. An acid cleaning system generally consists of an acid storage tank and a small acid recycle pump. The acid recycle pump can be plumbed into the union of the recycle pipe that connects to the building(s), and a return line can be laid on the ground to return the acid back to the storage tank. The circulating acid will dissolve any salt build-up in the recycle line(s). If an acid recycle system is desired, the small stud frame building could store the acid recycle system.

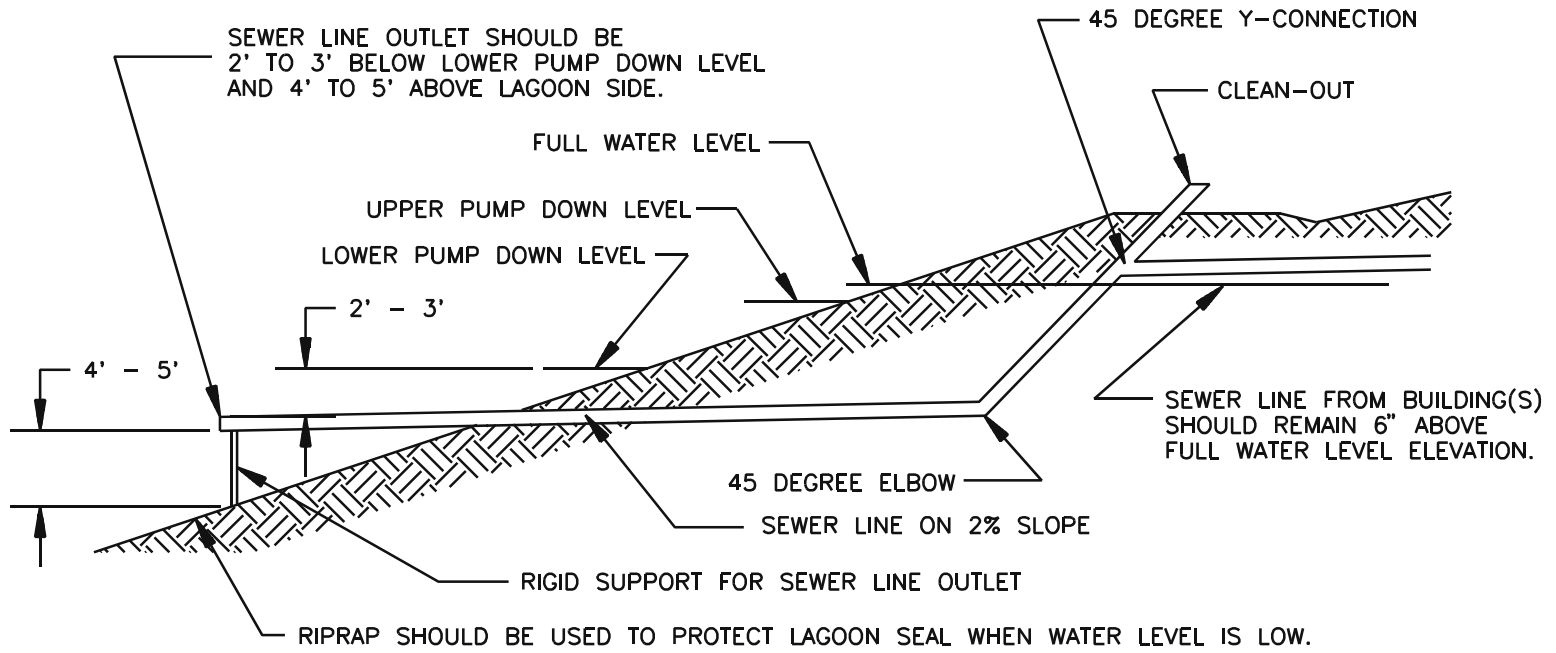

Figure 6. Scaled Sketch of Submerged Inlet into Anaerobic Lagoon.

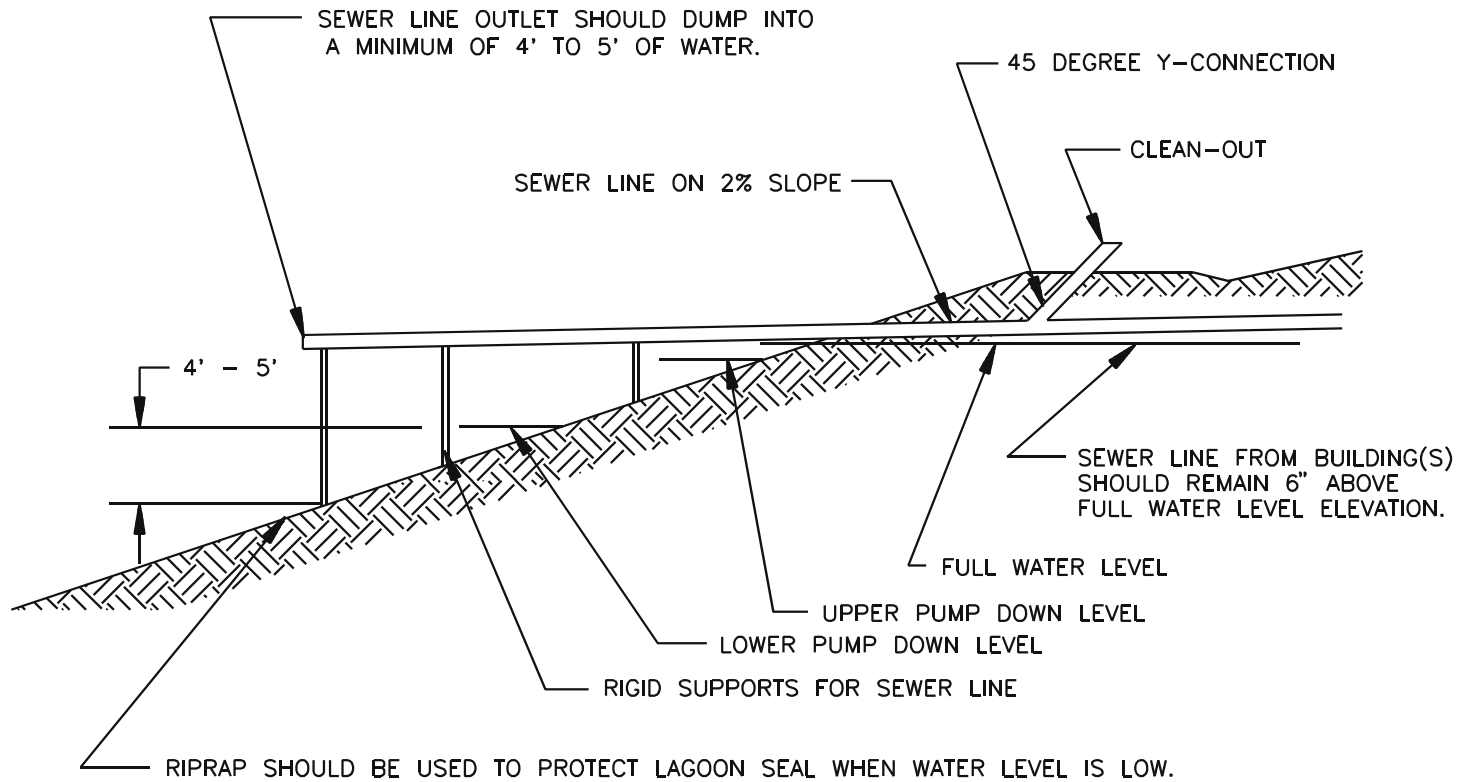

Figure 7. Scaled Sketch of Surface Inlet into Anaerobic Lagoon.

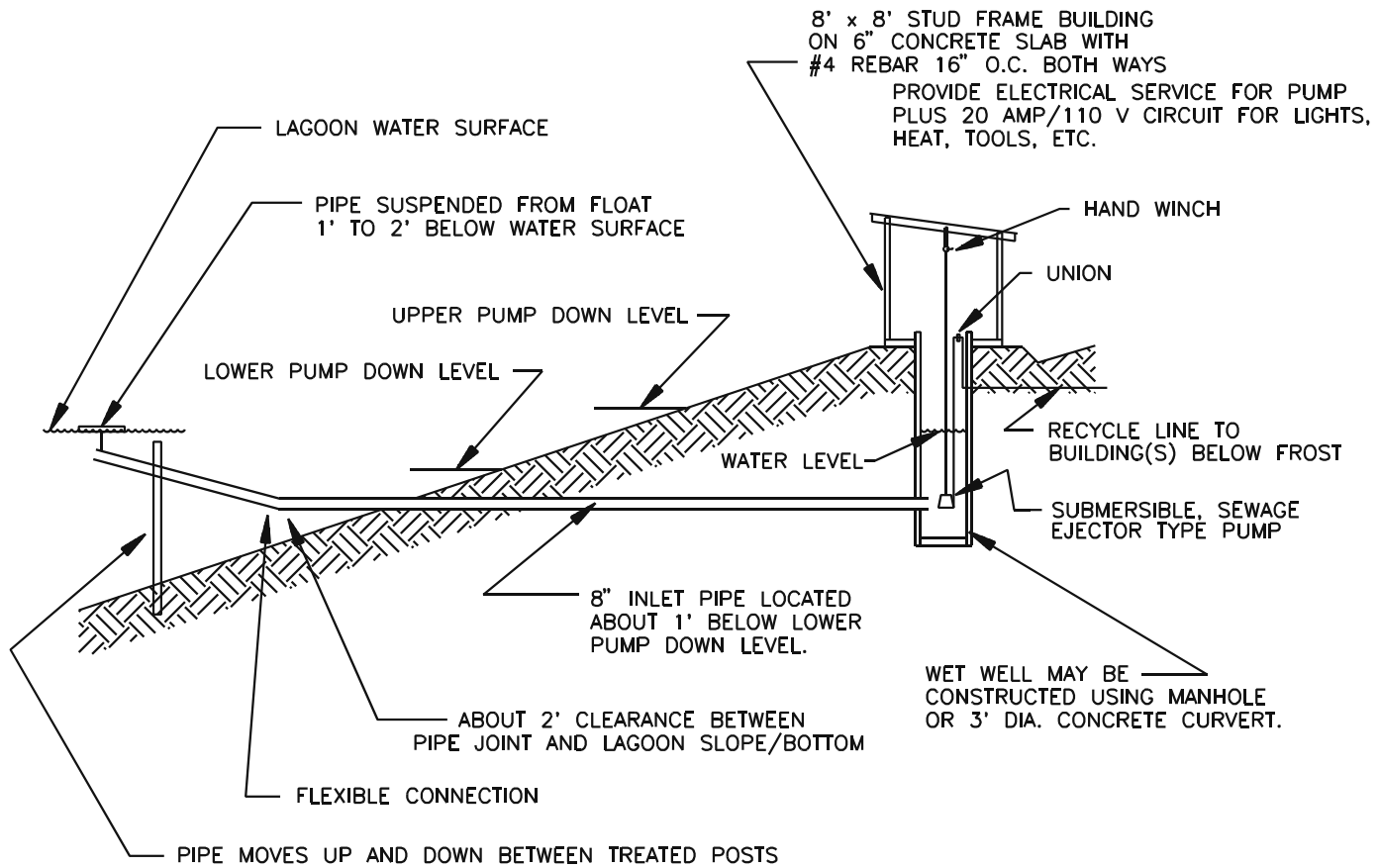

Figure 8. Scaled Sketch of Wet Well Installation for Lagoon Recycle Pump.

D. Concrete Manure Storages

The gravity drain gutter system allows for a liquid manure system. If the gravity drain gutter option is selected, an outside manure storage structure will be needed. Several types of structures are possible to serve as a liquid manure storage facility. Concrete manure storage facilities are probably the most common type of swine manure storage structure.

This MO-Flex Nursery Building Plan does not have a manure storage plan included with the building plan. Information for designing and constructing concrete manure storages is available [Concrete Manure Storages Handbook \(MWPS-36\)](#). This handbook provides design criteria, reinforcing selection and construction details for liquid manure storages. However, local requirements and conditions may require specific design changes. A liquid manure storage should be certified by an engineer to insure that the structure will meet the required loads and comply with an environmental regulations.

E. Fan Sizes With No Pit Ventilation

The fan performance specifications in this appendix are for a building using the flush manure handling option (i.e. no pit ventilation). The exhaust fan performance specifications are for nursery rooms capable of housing from 120 to 410 pigs.

Fan Requirements for a Nursery Room Housing 120-140 Pigs			
No Pit Ventilation			
Stage	Typical Fan Diameter and Type	Minimum Operating Rate (cfm)	Maximum Operating Rate (cfm)
1	6-8" variable speed*	140	420/450
2	16" variable speed	800/1200	2400
3	20" single speed		4000

Fan Requirements for a Nursery Room Housing 140-175 Pigs			
No Pit Ventilation			
Stage	Typical Fan Diameter and Type	Minimum Operating Rate (cfm)	Maximum Operating Rate (cfm)
1	6-8" variable speed*	175	525/600
2	16" variable speed	800/1200	2400
3	24" single speed		5500

Fan Requirements for a Nursery Room Housing 175-210 Pigs			
No Pit Ventilation			
Stage	Typical Fan Diameter and Type	Minimum Operating Rate (cfm)	Maximum Operating Rate (cfm)
1	8" variable speed	210	600
2	18" variable speed	1150/1750	3500
3	24" single speed		5500

Fan Requirements for a Nursery Room Housing 210-240 Pigs			
No Pit Ventilation			
Stage	Typical Fan Diameter and Type	Minimum Operating Rate (cfm)	Maximum Operating Rate (cfm)
1	6-8" single speed*		240
2	10" variable speed	500	1000
3	18" variable speed	1750	3500
4	24" single speed		5500

Fan Requirements for a Nursery Room Housing 240-270 Pigs			
No Pit Ventilation			
Stage	Typical Fan Diameter and Type	Minimum Operating Rate (cfm)	Maximum Operating Rate (cfm)
1	6-8" single speed*		270
2	10" variable speed	540	1000
3	18" variable speed	1750	3500
4	36" single speed		9000

Fan Requirements for a Nursery Room Housing 270-300 Pigs			
No Pit Ventilation			
Stage	Typical Fan Diameter and Type	Minimum Operating Rate (cfm)	Maximum Operating Rate (cfm)
1	10" variable speed	330	1000
2	24" variable speed	1800/2700	5500
3	36" single speed		9000

Fan Requirements for a Nursery Room Housing 300-350 Pigs			
No Pit Ventilation			
Stage	Typical Fan Diameter and Type	Minimum Operating Rate (cfm)	Maximum Operating Rate (cfm)
1	10" variable speed	350	1000
2	24" variable speed	1800/2750	5500
3	36" single speed		9000

Fan Requirements for a Nursery Room Housing 350-410 Pigs			
No Pit Ventilation			
Stage	Typical Fan Diameter and Type	Minimum Operating Rate (cfm)	Maximum Operating Rate (cfm)
1	12" variable speed	430	1300
2	18" variable speed	1150/1750	3500
3	24" single speed		5500
4	36" single speed		9000

F. Fan Sizes Using Pit Ventilation

Fan Requirements for a Nursery Room Housing 120-140 Pigs			
Pit Ventilation Provides Minimum Rate for Small Pigs			
Stage	Typical Fan Diameter and Type	Minimum Operating Rate (cfm)	Maximum Operating Rate (cfm)
1	Pit System		140
2	8" variable speed	300	600
3	14" variable speed	900	1800
4	24" single speed		5500

Fan Requirements for a Nursery Room Housing 140-175 Pigs			
Pit Ventilation Provides Minimum Rate for Small Pigs			
Stage	Typical Fan Diameter and Type	Minimum Operating Rate (cfm)	Maximum Operating Rate (cfm)
1	Pit System		175
2	8" variable speed	350	600
3	16" variable speed	1200	2400
4	24" single speed		5500

Fan Requirements for a Nursery Room Housing 175-210 Pigs			
Pit Ventilation Provides Minimum Rate for Small Pigs			
Stage	Typical Fan Diameter and Type	Minimum Operating Rate (cfm)	Maximum Operating Rate (cfm)
1	Pit System		210
2	8" variable speed	420	600
3	18" variable speed	1750	3500
4	24" single speed		5500

Fan Requirements for a Nursery Room Housing 210-240 Pigs			
Pit Ventilation Provides Minimum Rate for Small Pigs			
Stage	Typical Fan Diameter and Type	Minimum Operating Rate (cfm)	Maximum Operating Rate (cfm)
1	Pit System		240
2	10" variable speed	500	1000
3	16" variable speed	1200	2400
4	36" single speed		9000

Fan Requirements for a Nursery Room Housing 240-270 Pigs			
Pit Ventilation Provides Minimum Rate for Small Pigs			
Stage	Typical Fan Diameter and Type	Minimum Operating Rate (cfm)	Maximum Operating Rate (cfm)
1	Pit System		270
2	10" variable speed	540	1000
3	18" variable speed	1750	3500
4	36" single speed		9000

Fan Requirements for a Nursery Room Housing 270-300 Pigs			
Pit Ventilation Provides Minimum Rate for Small Pigs			
Stage	Typical Fan Diameter and Type	Minimum Operating Rate (cfm)	Maximum Operating Rate (cfm)
1	Pit System		300
2	12" variable speed	650	1300
3	20" variable speed	2000	4000
4	36" single speed		9000

Fan Requirements for a Nursery Room Housing 300-350 Pigs			
Pit Ventilation Provides Minimum Rate for Small Pigs			
Stage	Typical Fan Diameter and Type	Minimum Operating Rate (cfm)	Maximum Operating Rate (cfm)
1	Pit System		350
2	12" variable speed	700	1300
3	24" variable speed	2750	5500
4	36" single speed		9000

Fan Requirements for a Nursery Room Housing 350-410 Pigs			
Pit Ventilation Provides Minimum Rate for Small Pigs			
Stage	Typical Fan Diameter and Type	Minimum Operating Rate (cfm)	Maximum Operating Rate (cfm)
1	Pit System		410
2	12" variable speed	820	1300
3	18" variable speed	1750	3500
4	24" single speed		5500
5	36" single speed		9000

G. Pit Ventilation Pipe Designs for Pit Ventilation

Fan Rating: 48 cfm @ 0.10" S.P. Pipe Size: 6" Pipe Length: 16' Hole Size1: 7/8" @ 4 & 8 o'clock			
Location from fan ²	Distance from fan ³	Location from fan ²	Distance from fan ³
1	1' 3"	4	8' 8"
2	3' 8½"	5	11' 2"
3	6' 2½"	6	13' 7½"

¹For a given location. Hole size gives the size of the 2 holes drilled at the 4 and 8 o'clock positions.

²Locations from fan are the positions down the length of the pipe from the fan or the end of the gutter that has the fan.

³Distance from fan or end of gutter with fan to the center of the holes.

Fan Rating: 72 cfm @ 0.10" S.P. Pipe Size: 6" Pipe Length: 24' Hole Size¹: 7/8" @ 4 & 8 o'clock			
Location from fan ²	Distance from fan ³	Location from fan ²	Distance from fan ³
1	1' 2½"	6	13' 3"
2	3' 7½"	7	15' 7½"
3	6' ½"	8	18' ½"
4	8' 5½"	9	20' 5½"
5	10' 10"	10	22' 10"

¹For a given location. Hole size gives the size of the 2 holes drilled at the 4 and 8 o'clock positions.

²Locations from fan are the positions down the length of the pipe from the fan or the end of the gutter that has the fan.

³Distance from fan or end of gutter with fan to the center of the holes.

Fan Rating: 96 cfm @ 0.10 S.P. Pipe Size: 6" Pipe Length: 32' Hole Size¹: 7/8			
Location from fan ²	Distance from fan ³	Location from fan ²	Distance from fan ³
1	1' 2"	8	17' 2½"
2	3' 6"	9	19' 5½"
3	5' 9½"	10	21' 9"
4	8' 1"	11	24' 0"
5	10' 4½"	12	26' 3½"
6	12' 8"	13	28' 6½"
7	14' 11"	14	30' 10"

¹For a given location. Hole size gives the size of the 2 holes drilled at the 4 and 8 o'clock positions.

²Locations from fan are the positions down the length of the pipe from the fan or the end of the gutter that has the fan.

³Distance from fan or end of gutter with fan to the center of the holes.

Fan Rating: 108 cfm @ 0.10" S.P. Pipe Size: 6" Pipe Length: 36' Hole Size¹: 7/8" @ 4 & 8 o'clock			
Location from fan ²	Distance from fan ³	Location from fan ²	Distance from fan ³
1	1' 1½"	9	18' 10½"
2	3' 5"	10	21' ½"
3	5' 7½"	11	23' 2½"
4	7' 10½"	12	25' 5"
5	10' 1"	13	27' 7"
6	12' 3½"	14	29' 9"
7	14' 6"	15	31' 11"
8	16' 8"	16	34' 1"

¹For a given location. Hole size gives the size of the 2 holes drilled at the 4 and 8 o'clock positions.

²Locations from fan are the positions down the length of the pipe from the fan or the end of the gutter that has the fan.

³Distance from fan or end of gutter with fan to the center of the holes.

Fan Rating: 120 cfm @ 0.10" S.P. Pipe Size: 6" Pipe Length: 40' Hole Size¹: 7/8" @ 4 & 8 o'clock			
Location from fan ²	Distance from fan ³	Location from fan ²	Distance from fan ³
1	1' 1"	10	20' 3"
2	3' 3½"	11	22' 3½"
3	5' 5½"	12	24' 4½"
4	7' 7½"	13	26' 5½"
5	9' 9"	14	28' 6"
6	11' 10½"	15	30' 7"
7	14' 0"	16	32' 7½"
8	16' 1"	17	34' 8½"
9	18' 2"	18	36' 9"
		19	38' 10"

¹For a given location. Hole size gives the size of the 2 holes drilled at the 4 and 8 o'clock positions.

²Locations from fan are the positions down the length of the pipe from the fan or the end of the gutter that has the fan.

³Distance from fan or end of gutter with fan to the center of the holes.

Fan Rating: 144 cfm @ 0.10" S.P. Pipe Size: 6" Pipe Length: 48' Hole Size¹: 7/8" @ 4 & 8 o'clock			
Location from fan ²	Distance from fan ³	Location from fan ²	Distance from fan ³
1	1' 0"	14	25' 5½"
2	3' ½"	15	27' 2½"
3	5' ½"	16	28' 11½"
4	7' 0"	17	30' 9"
5	8' 11½"	18	32' 6"
6	10' 10"	19	34' 3"
7	12' 9"	20	36' 0"
8	14' 7"	21	37' 9"
9	16' 5"	22	39' 6"
10	18' 3"	23	41' 3"
11	20' 1"	24	43' 0"
12	21' 10½"	25	44' 9"
13	23' 8"	26	46' 6"

¹For a given location. Hole size gives the size of the 2 holes drilled at the 4 and 8 o'clock positions.

²Locations from fan are the positions down the length of the pipe from the fan or the end of the gutter that has the fan.

³Distance from fan or end of gutter with fan to the center of the holes.